

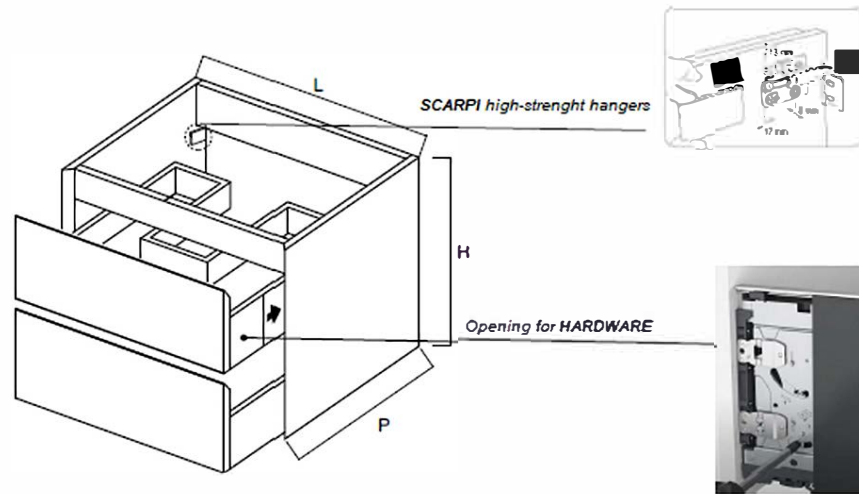

INSTALLATION INSTRUCTIONS



·DRAWERS:

- Runner AvanTech YOU model 
- Full extension runner
- Brake system at opening and closing
- Silent System technology
- Allows height adjustment 2mm and width adjustment +1.5mm
- Load capacity 30kg/drawer
- Drawer base: 16mm melamine particules anthracite
- Drain pipe: stainless steel in anthracite (for vanity unities only)

·TECHNICAL CHARACTERISTICS

- Cabinet suspension: SCARPI high strength model (INDAUX) that can withstand 65kg/each

HANDLE	MATERIAL	H	P	L
MITRA/CLOU	MDF	27-36-54-75	35 HASTA 50	60 HASTA 120

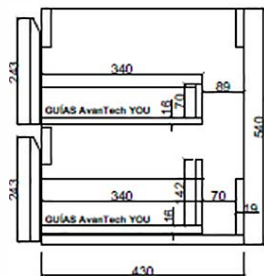

SECTION

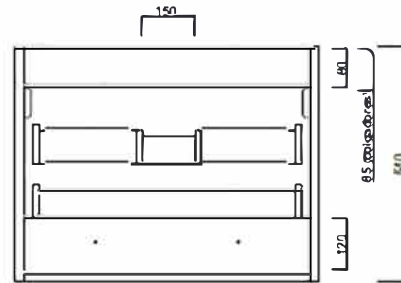

BACK ELEVATION



004