



# Claybrook.

**PRODUCT DATA SHEET**

**SHO-BRO-CON-1OT** (VCS201-TM) Trim set  
for 1 outlet Thermostatic Valve - metal lever

---





# Claybrook.

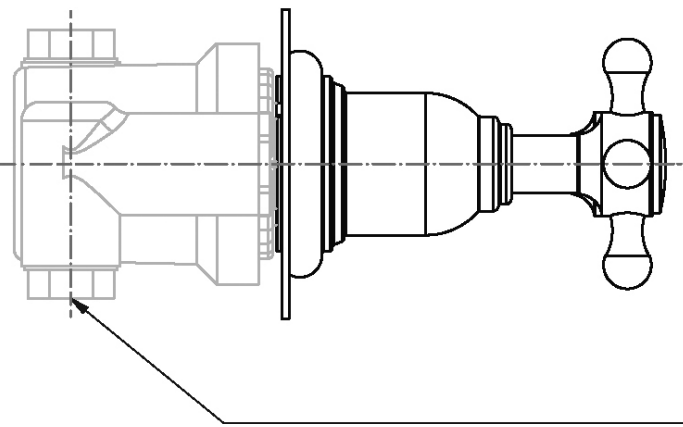
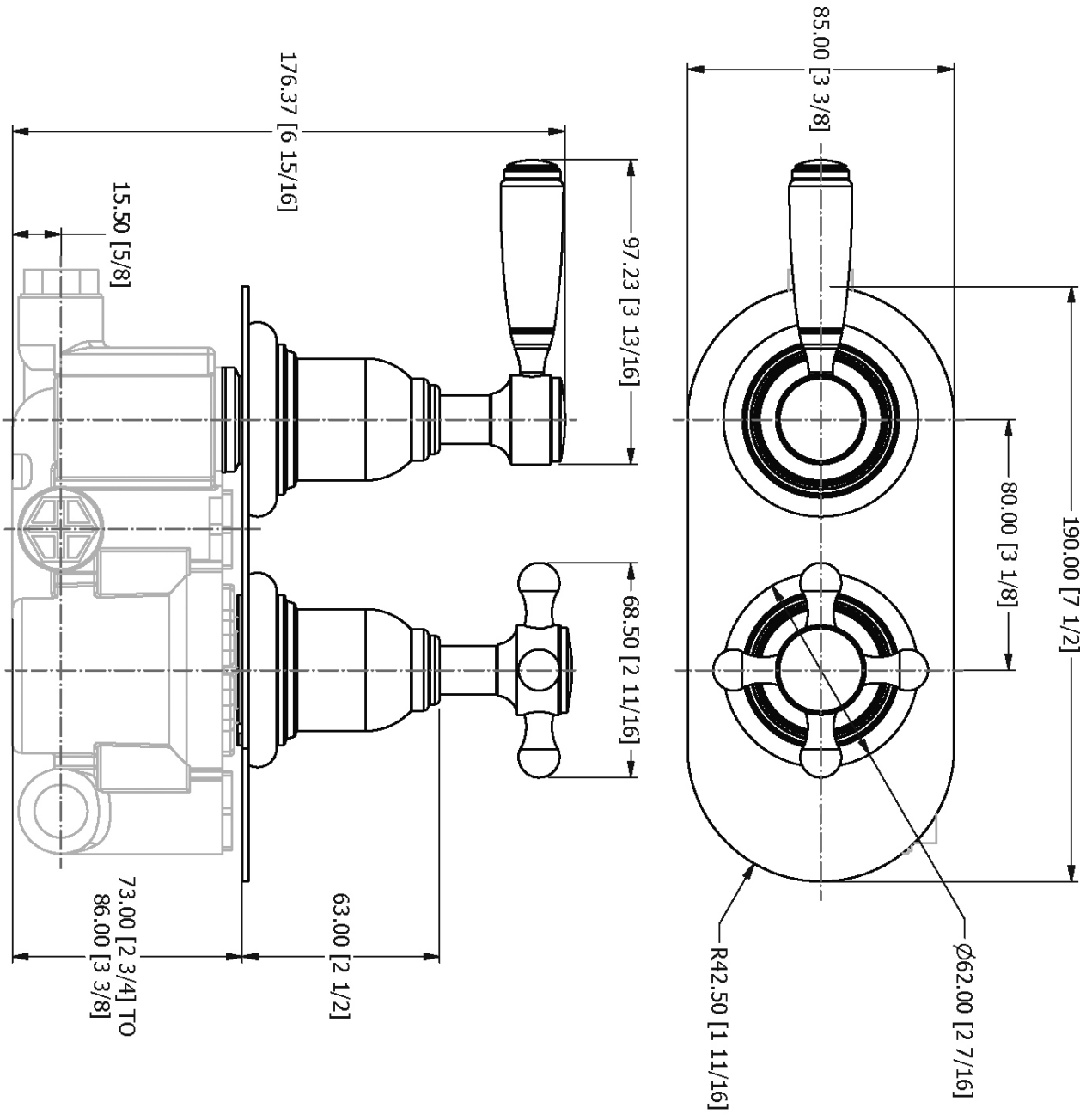

SEE INSTALLATION KIT DRAWING  
VCS134-IS

# Spares Information

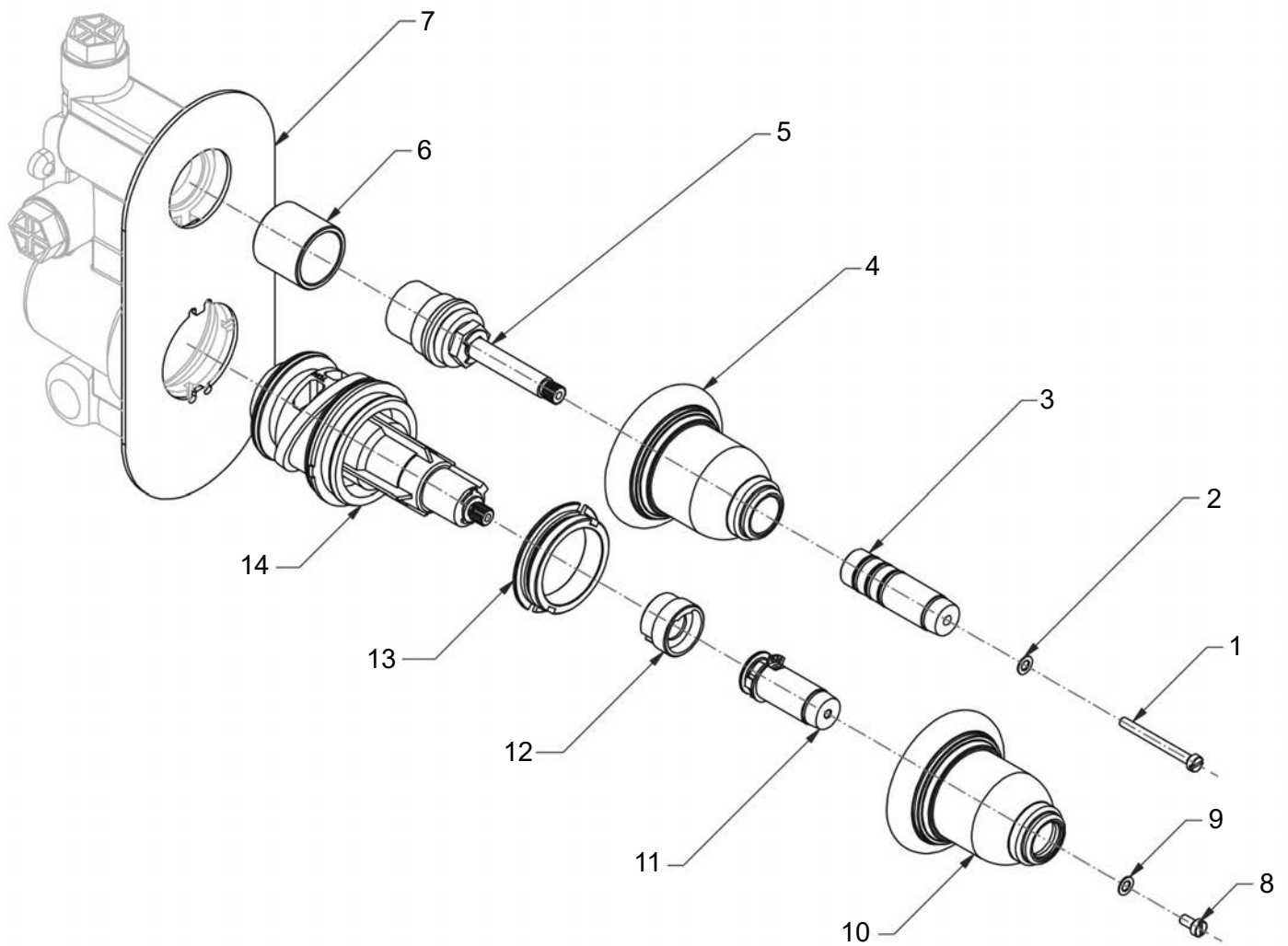

Item	Part No.	Description
1	-	Cheese Head Screw
2	-	Washer
3	-	Volume Spindle
4	-	Volume Body
5	-	CD Valve (Clockwise Closing)
6	-	Threaded Shank
7	-	Shower Plate
8	-	Cheese Head Screw
9	-	Washer
10	-	Thermo Body
11	-	Thermo Spindle
12	-	Thermo Locking Nut
13	-	Thermo Collar
14	-	Thermostatic Cartridge

# Claybrook.

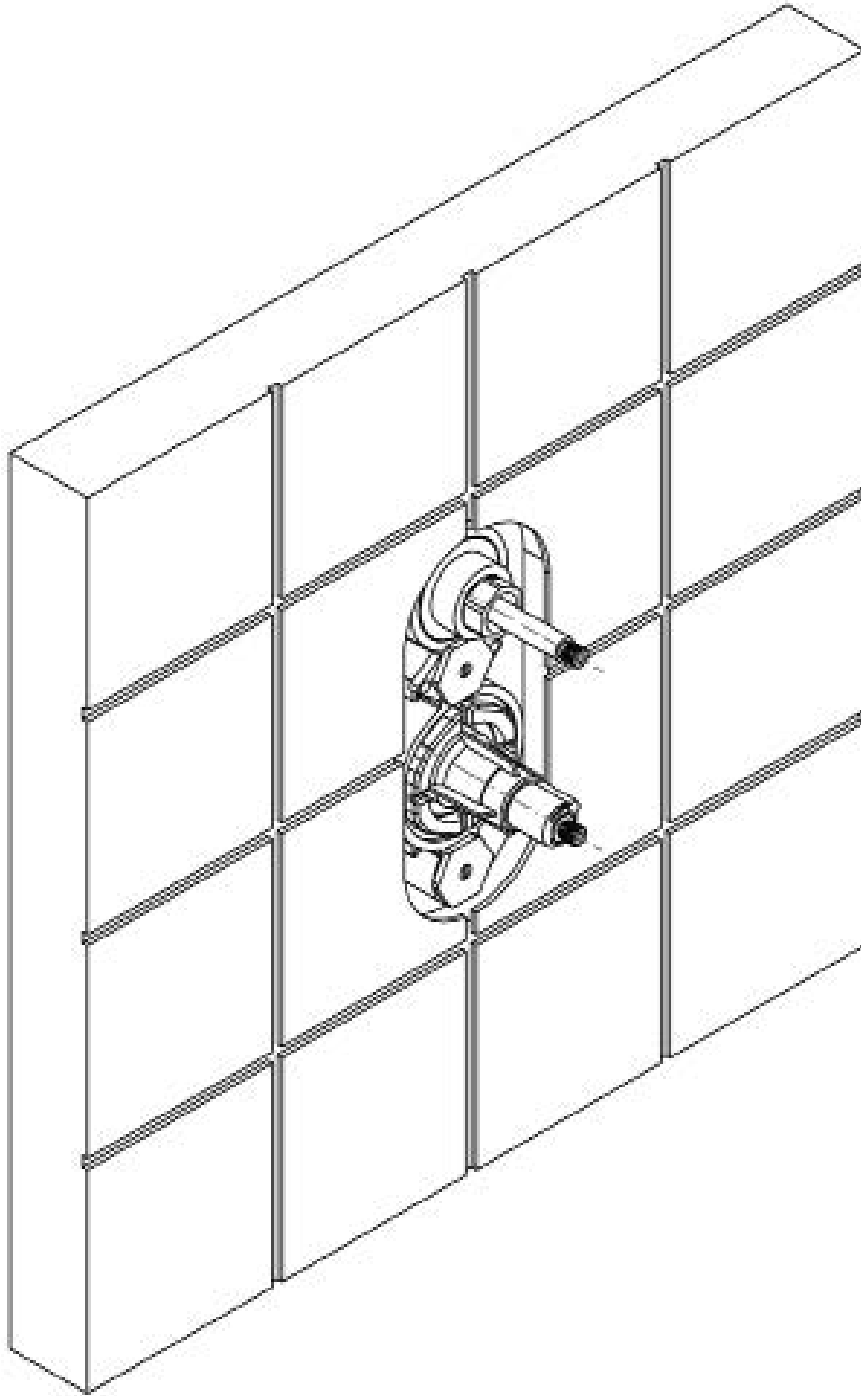

1. Install the finished surface, ensuring the finished surface is in accordance with the minimum and maximum installation depths shown on the drawings in the front of this booklet.

## Set Up

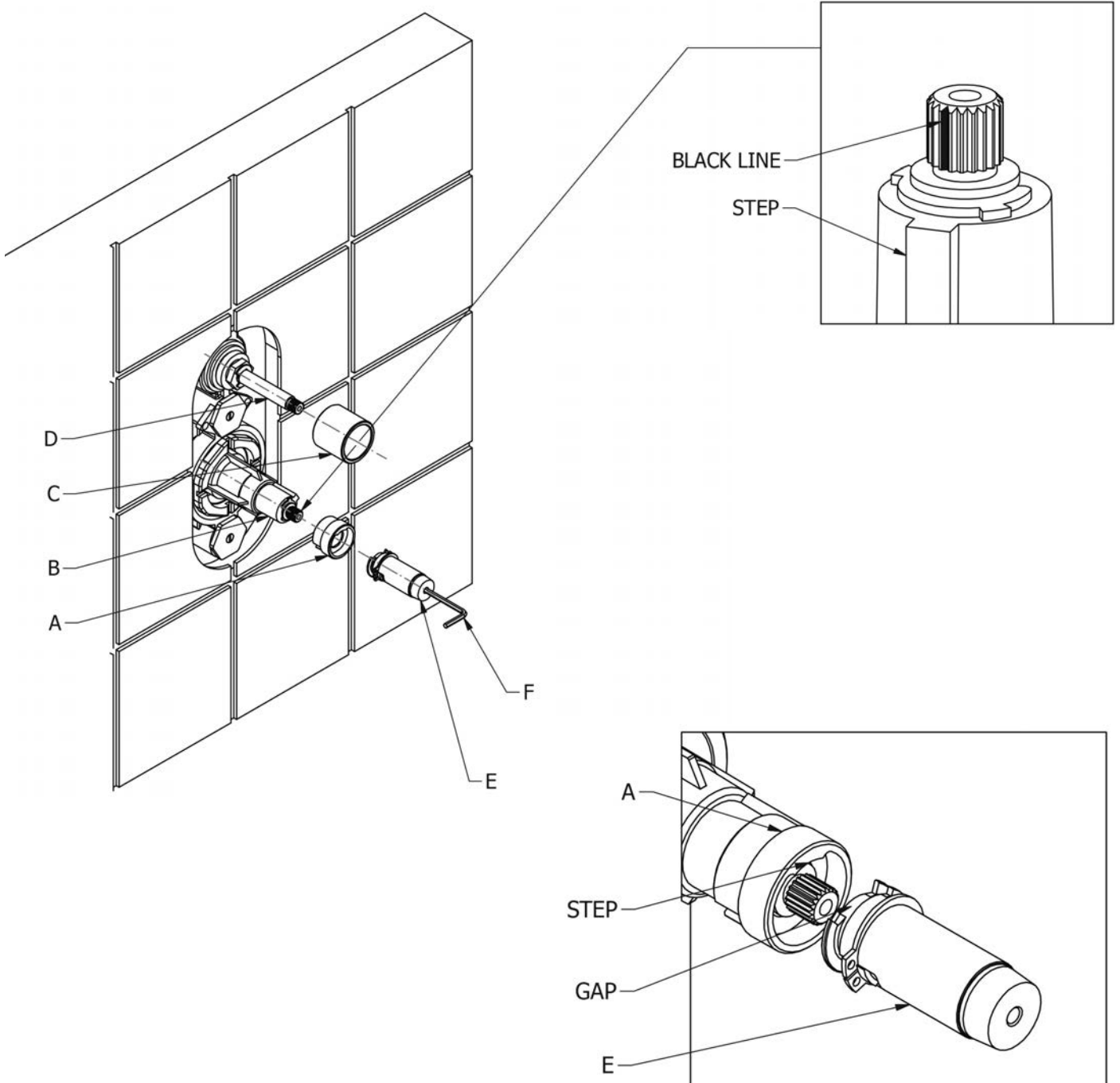

2. Ensure that the black line on the temperature spline (B) is in line with the step on the cartridge.

3. Push temperature ring (A) onto temperature cartridge (B).

4. Attach spindle assembly (E) onto the temperature cartridge (B) ensuring that the step on the temperature ring (A) lines up with the gap on the spindle assembly (E).

5. Secure the spindle in place by accessing the concealed screw in the spindle assembly (E) using Allen key (F).

6. Screw volume collar (C) onto the volume cartridge (D).

# Claybrook.

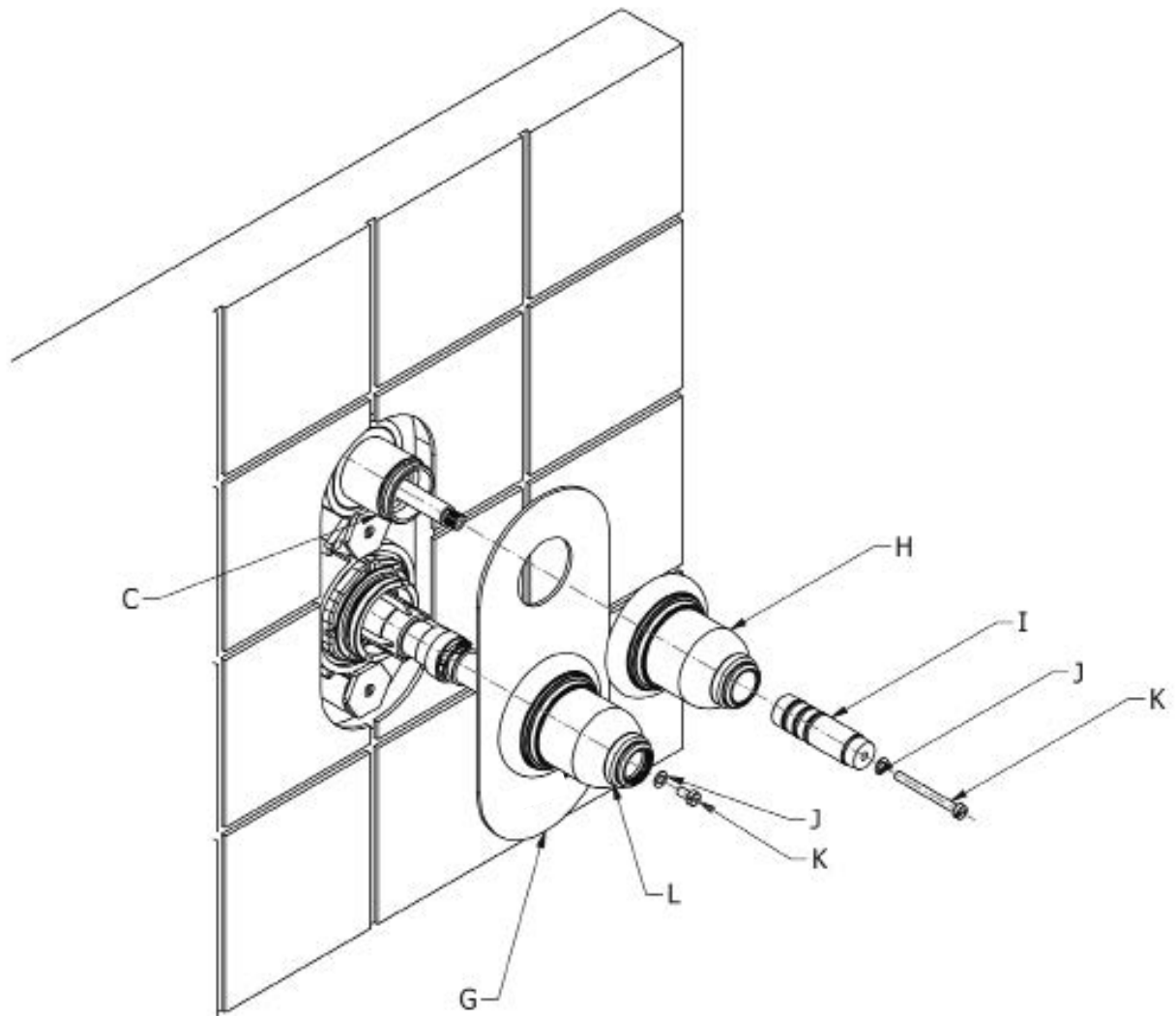

7. Apply a bead of silicon sealant to the wall where the trim plate assembly (G) will sit.
8. Push trim plate assembly (G) onto the installed shower.
9. Clamp the trim plate assembly in place by screwing the temperature body (H) onto the threaded shank (C).
10. Assemble the spindle (I), washer (J) and screw (K).

# Claybrook.

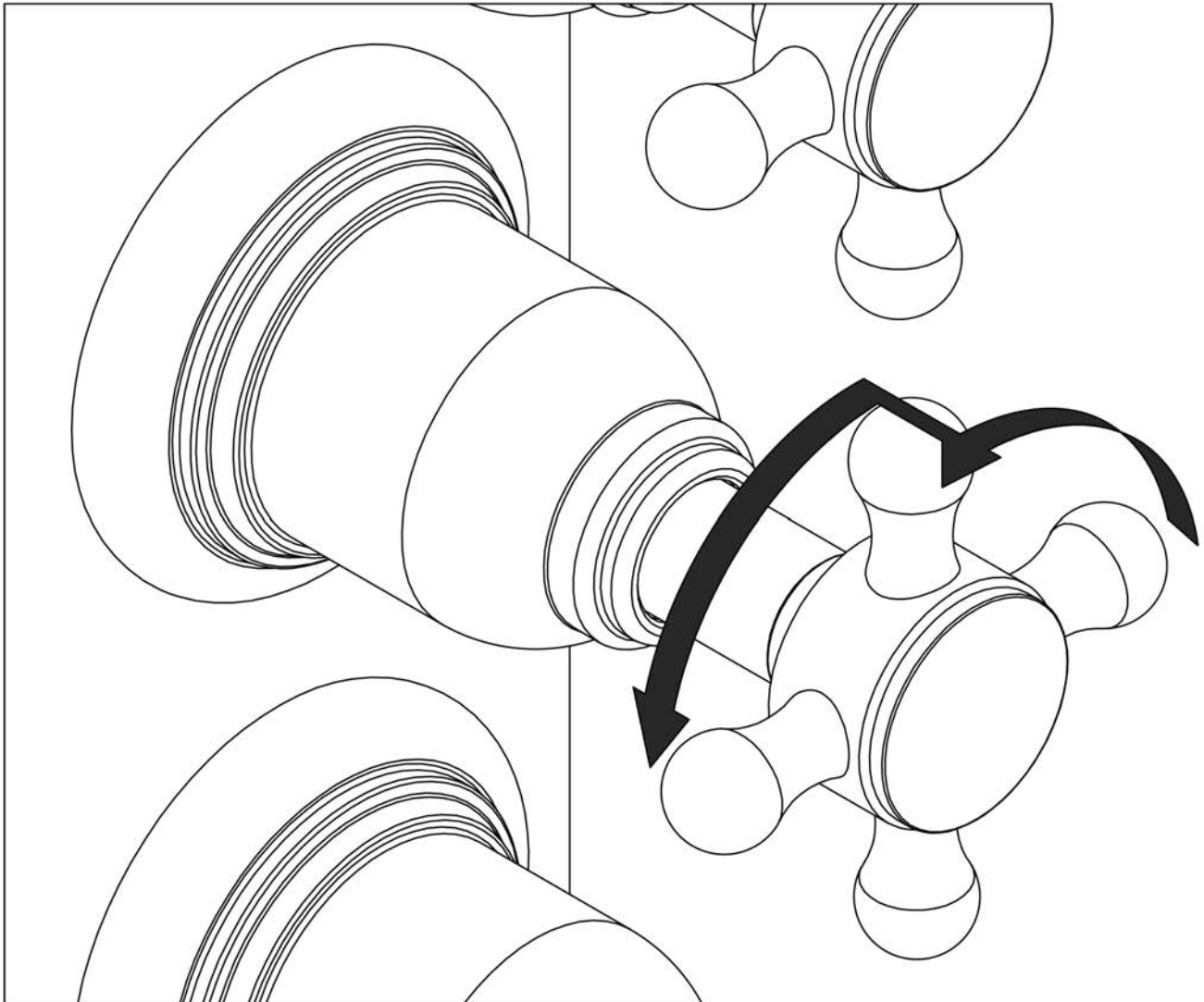

- This product has a pre-set maximum temperature of 41°C - 43°C (106°F - 109°F)
- An additional temperature increase is available by pressing in the sprung loaded cross top as shown at the maximum setting.
- The unit automatically clicks back into pre-override when rotated back towards cold.
- For further temperature increases, please see “Adjusting The Temperature”



# Claybrook.

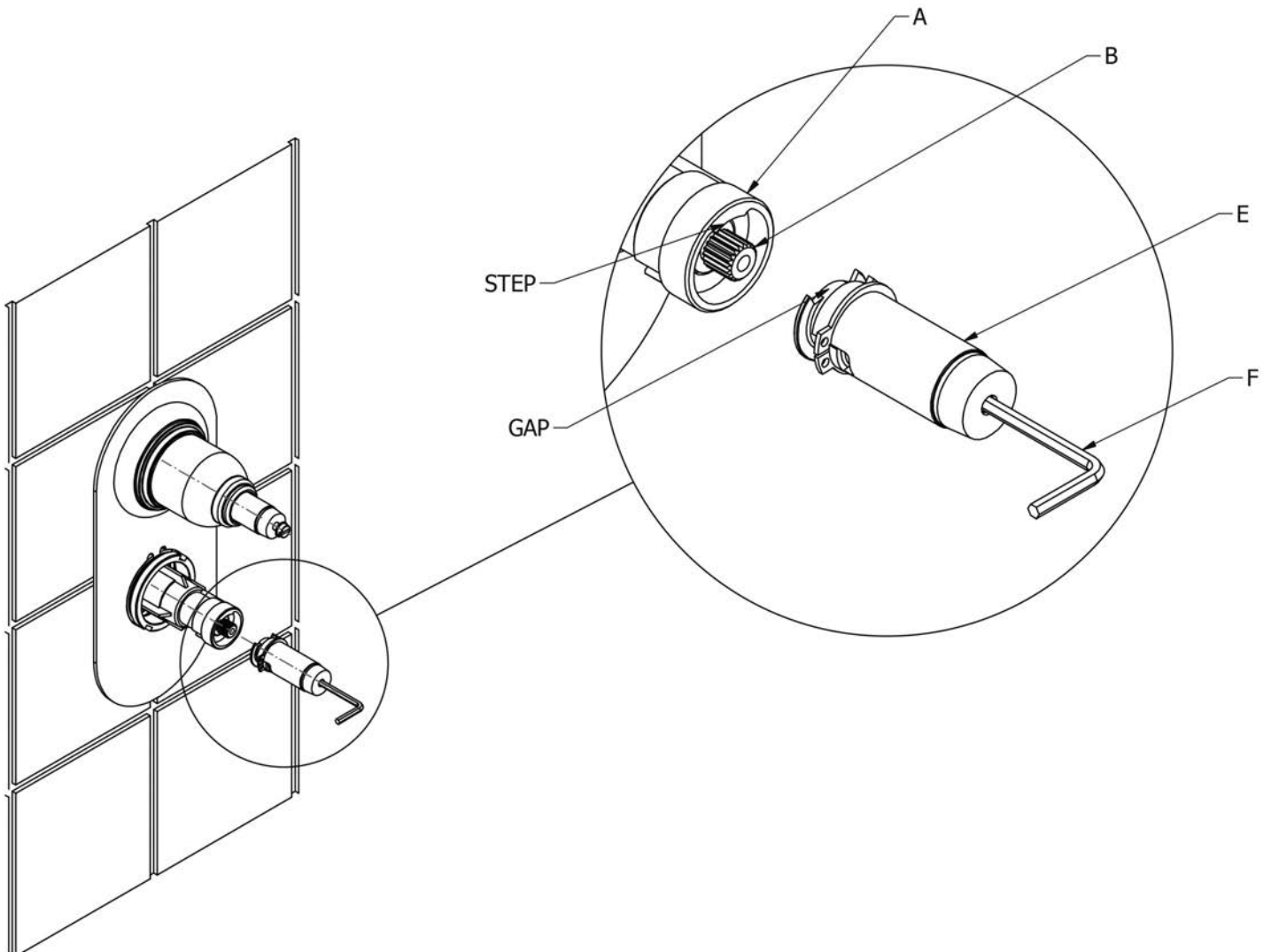

1. Remove thermo body (L).
2. Remove spindle assembly (E) by accessing the concealed screw using Allen key (F).

**Note:** To remove the spindle assembly (E), the gap in the spindle assembly (E) must be in line with the step on the temperature collar (A).

3. Rotate the spindle anti-clockwise to make the water hotter, and clockwise for colder.
4. Reassemble the spindle assembly (E).





# Claybrook.

## IMPORTANT NOTES

1. Installation should be carried out by a competent engineer, in accordance with water regulations.
2. Before installation, ensure supply pipes are flushed clean. Debris or loose particles will affect the efficiency of the ceramic disc cartridge.
3. For mixer taps, it is recommended that hot & cold pressures are equally balanced.
4. To help maintain the high quality finish, please clean with a soft damp cloth. Do not use abrasive polish or cleaners. Stains may be removed using undiluted washing up liquid.
5. Ceramic cartridges in hard water areas. To prolong the lifespan and reduce servicing periods of your tap we recommend that a suitable water softener be fitted. Consult your installer/designer for details.
6. Please note that as with all tap and shower ware it will be necessary from time to time for the products to be serviced, this should be carried out by a qualified Plumbing Engineer.

**Claybrook  
123 Curtain Road  
Shoreditch  
London  
EC2A 3BX**

**Tel: 020 7052 1555**

8-40387-CS